

TKH-TB50-F2-MODUL



PRODUCT FEATURES

- Trackball built-in panel for industrial environment
- Vandal-resistant stainless steel buttons
- Robust, resistant and durable
- Resistant to dirt, dust and liquid
- Integrated 50 mm trackball

SPECIFICATION

Number of keys:	3
Mounting typ:	front panel with threaded bolts
Frontpanel material:	brushed stainless steel
Keyswitch technology:	short travel keys
Switching cycles:	approx. 1 mill. (per key)
Operating force:	4.0 N
Switch travel:	1.3 mm
Protection level:	IP65 (stat.), IP54 (dyn.) (frontside)
Interface:	USB; PS/2 (via adapter)
Operating temperature:	-10 °C to +60 °C
Storage temperature:	-25 °C to +80 °C

Dimensions:	100 x 116 x 40 mm
Weight:	600 g
Certifications:	RohS, REACH, EMC

SPECIFICATION TRACKBALL

Material:	phenolic
Operating principle:	mechanical
Lifetime:	2 mill. ball revolutions
Actuation force:	50 g
Diameter:	50.8 mm

Cat.No.	Product description
KH16229	TKH-TB50-F2-MODUL-PS2/USB

Other language versions/interfaces/configurations available on request

Subject to modifications and errors!

TECHNICAL DRAWING (in mm)

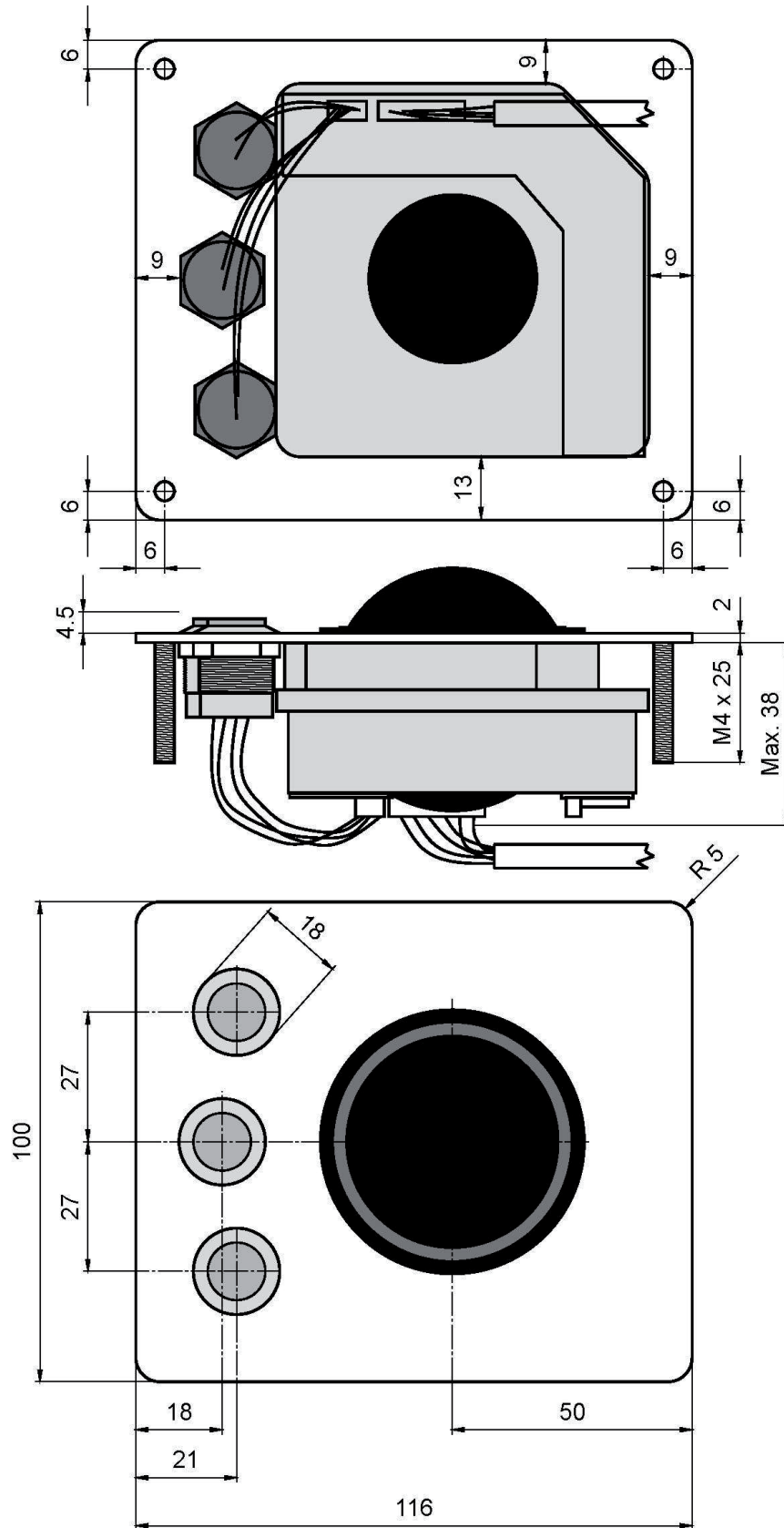

Subject to modifications and errors!